

Aufbauformen

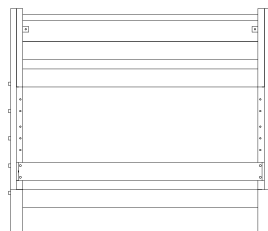

Hochbett

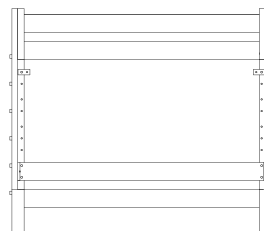

Jugendbett

Wichtig! Important!

Für die Montage benötigen Sie



Achten Sie bei der Benutzung des oberen Bettes durch Kleinkinder (unter 6 Jahren) auf die Gefahr des Herunterfallens. Pay attention to be risk of falling down at the use of the upper bed by small children (less than 6 years).

Die Dicke der Matratze darf nicht mehr als 14,8 cm betragen. The thickness of the mattress may not behave any more than 14,8 cm.

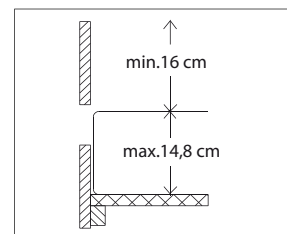

Eine saubere Unterlage erleichtert Ihnen die Arbeit.

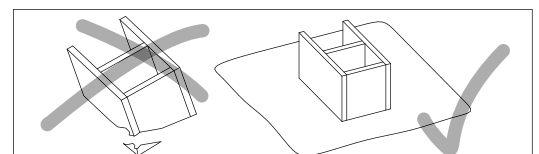

Hotline

0049-(0)221-473260

Hochbett

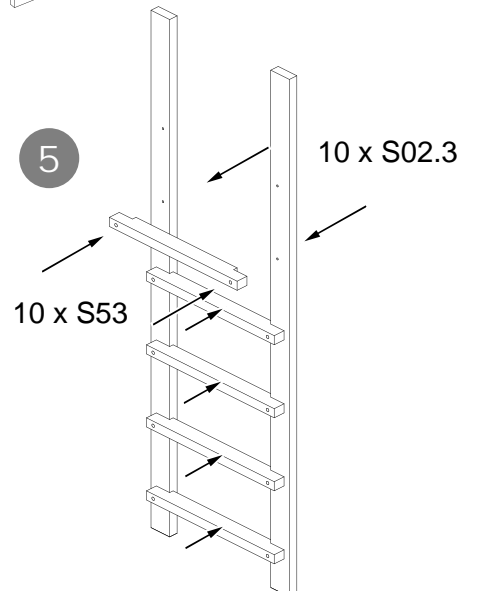
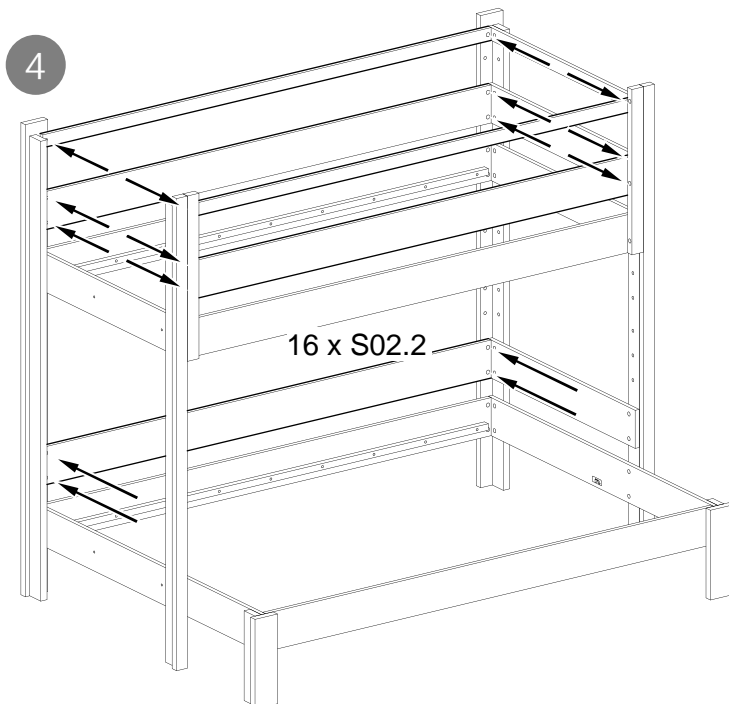
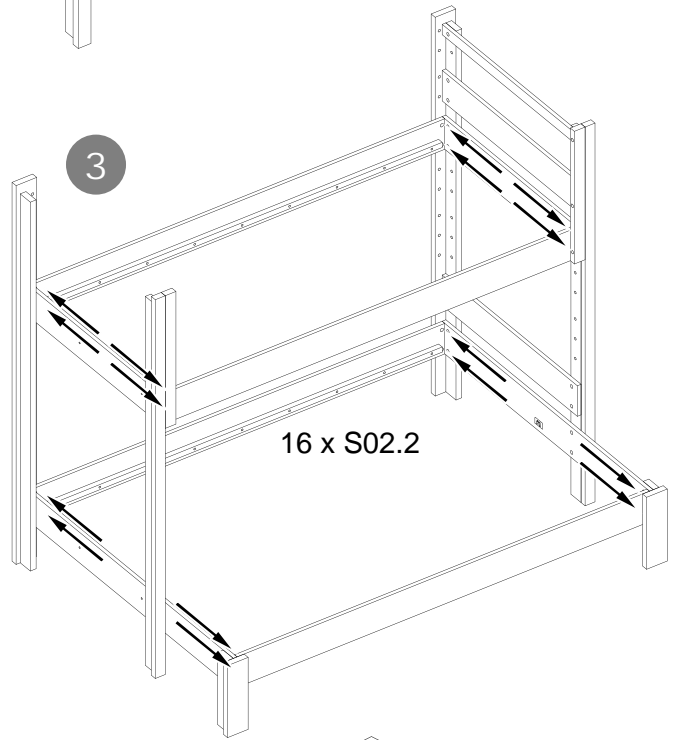
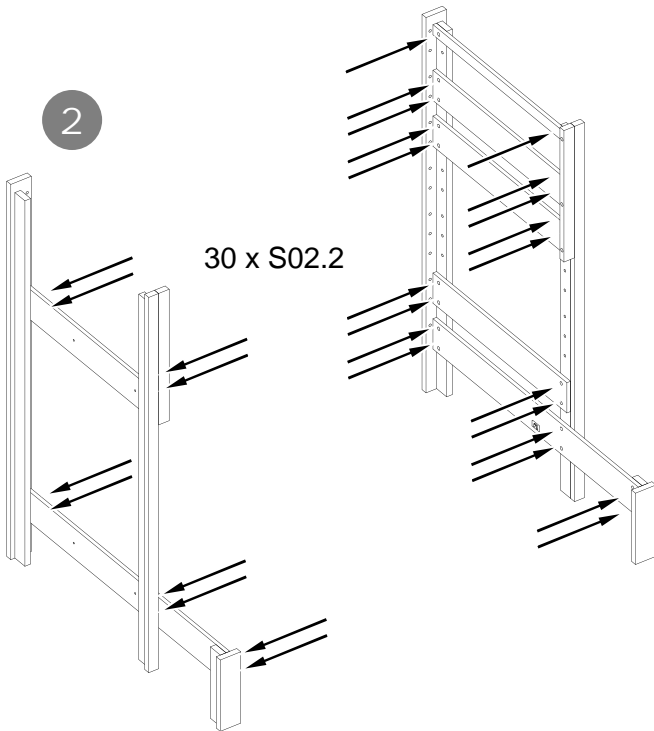
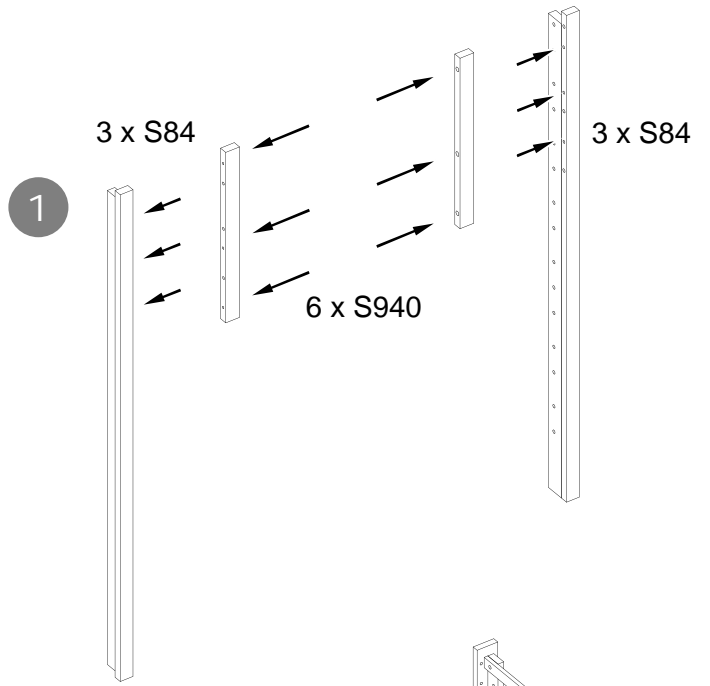
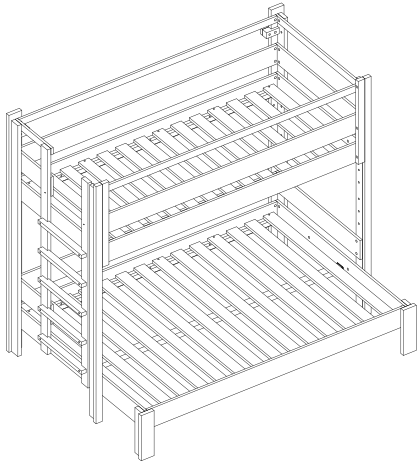

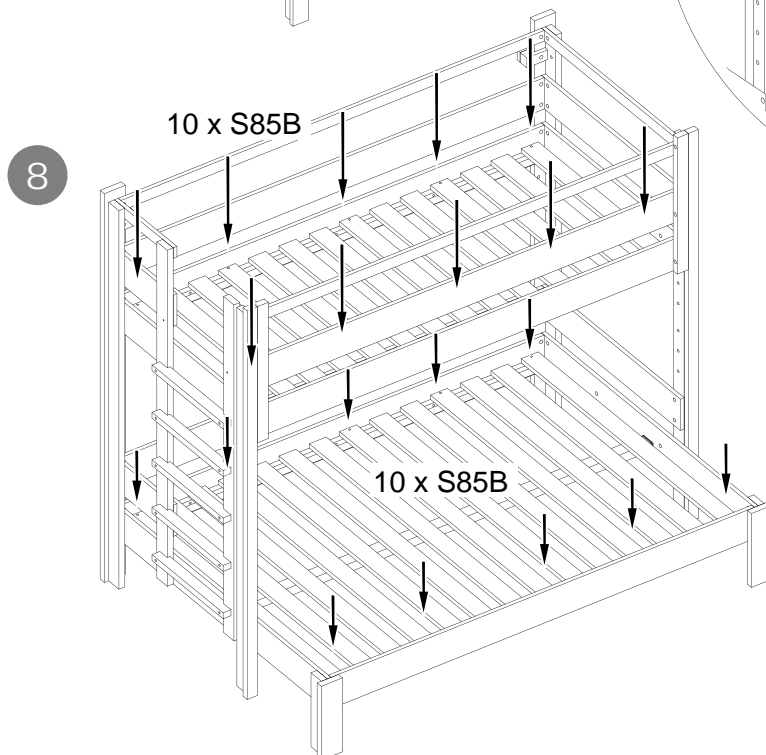
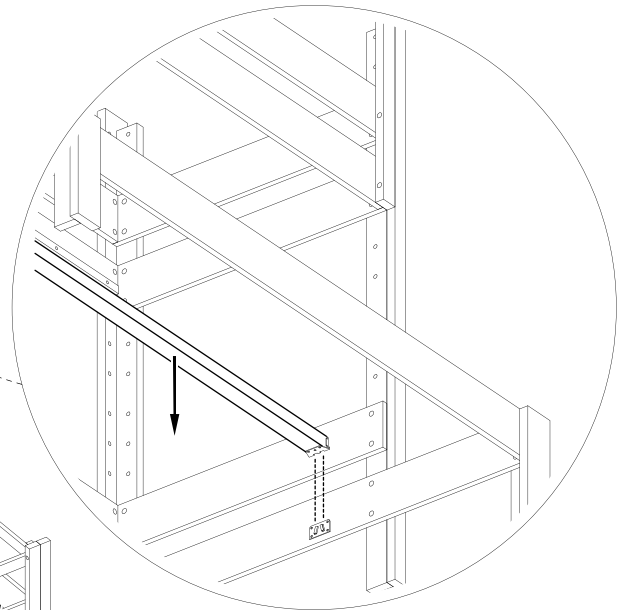
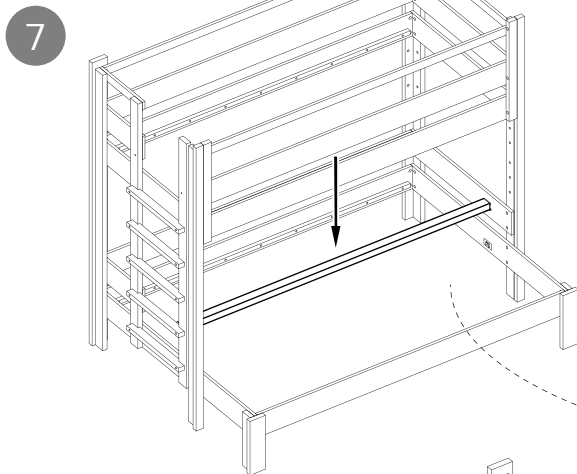
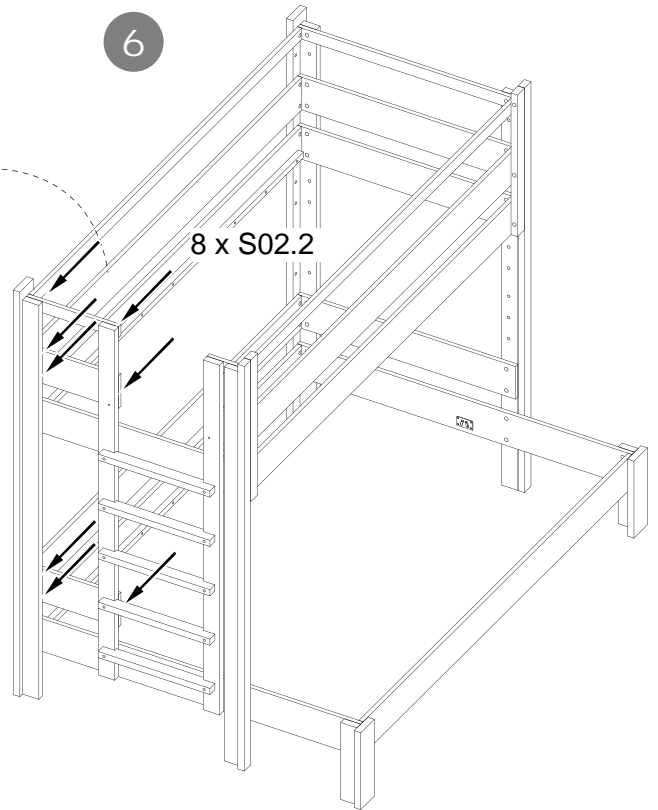
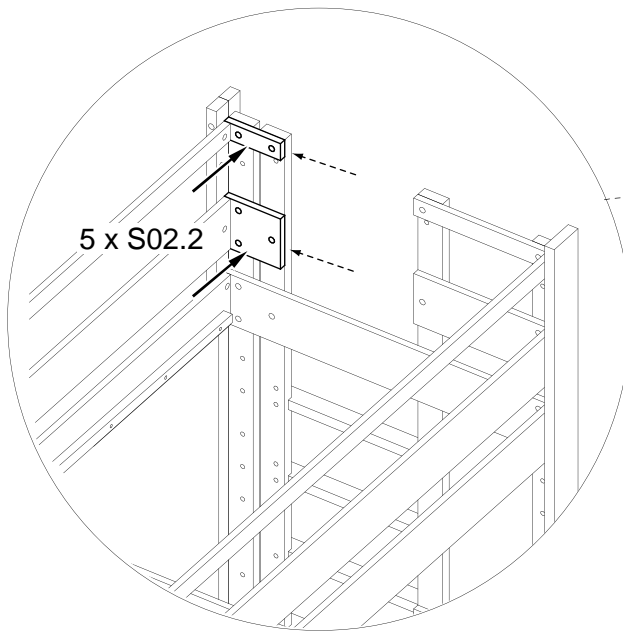

Jugendbett

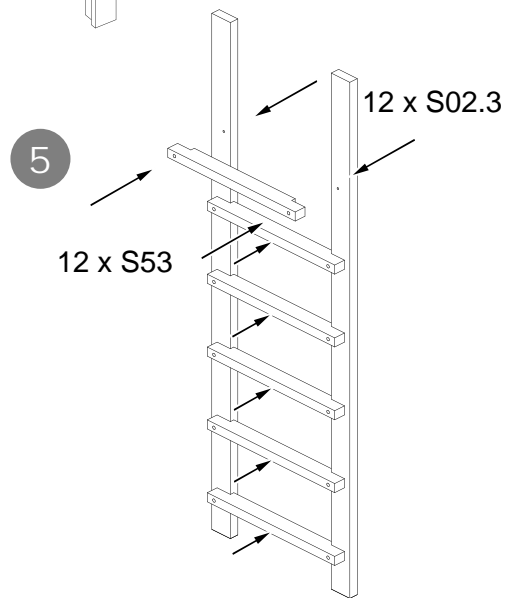
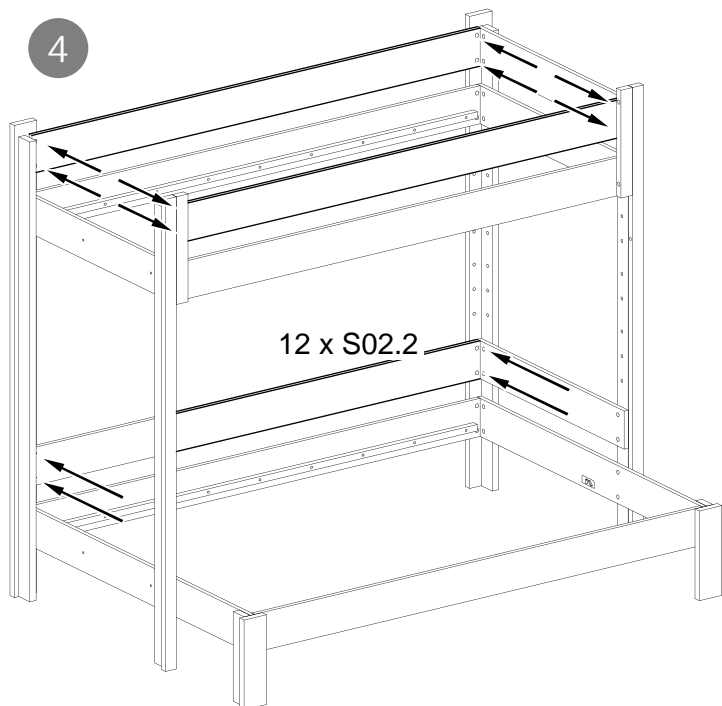
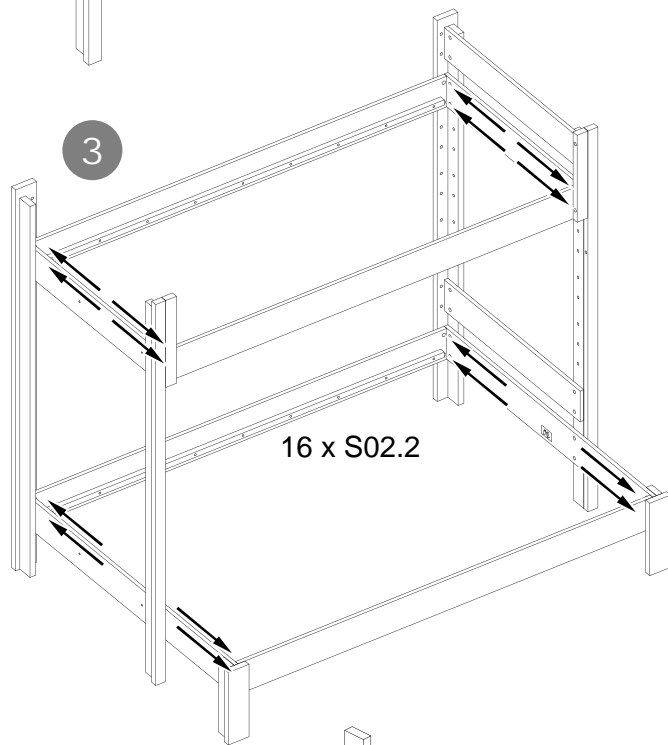
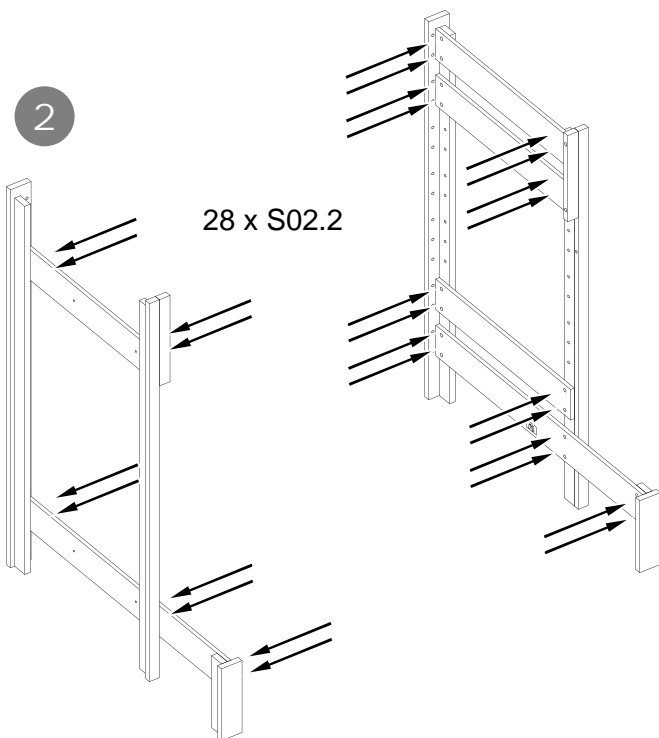
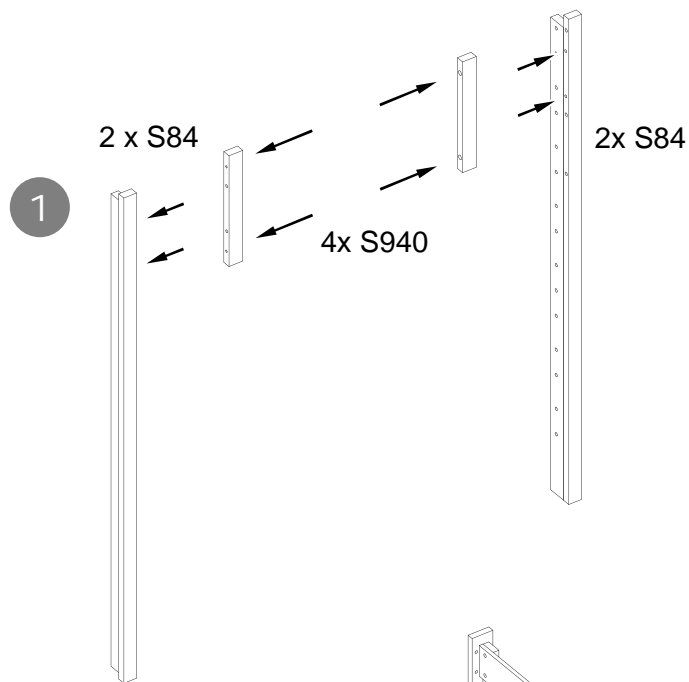
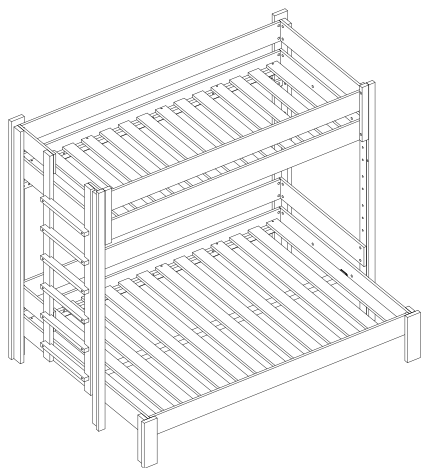

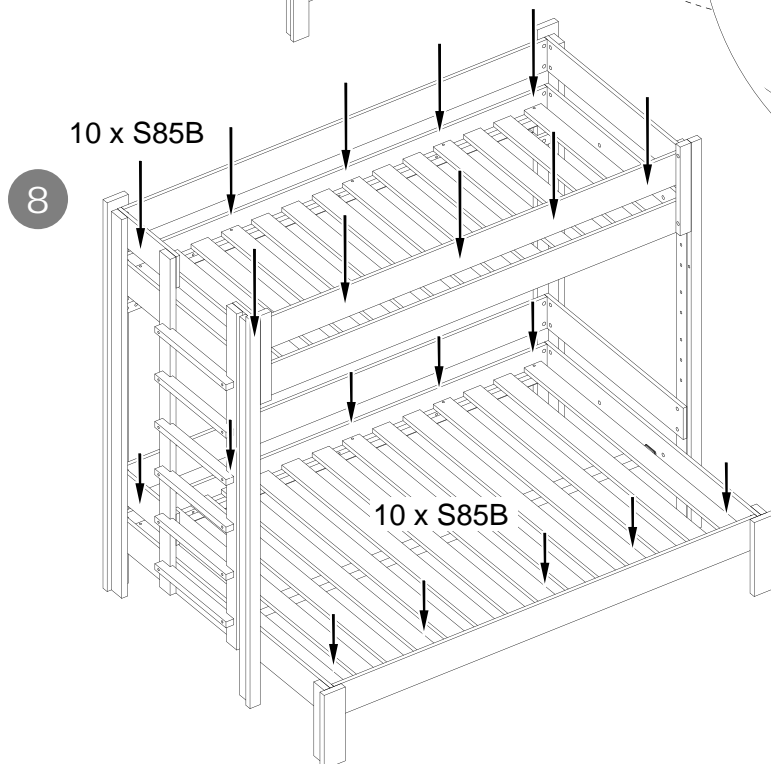
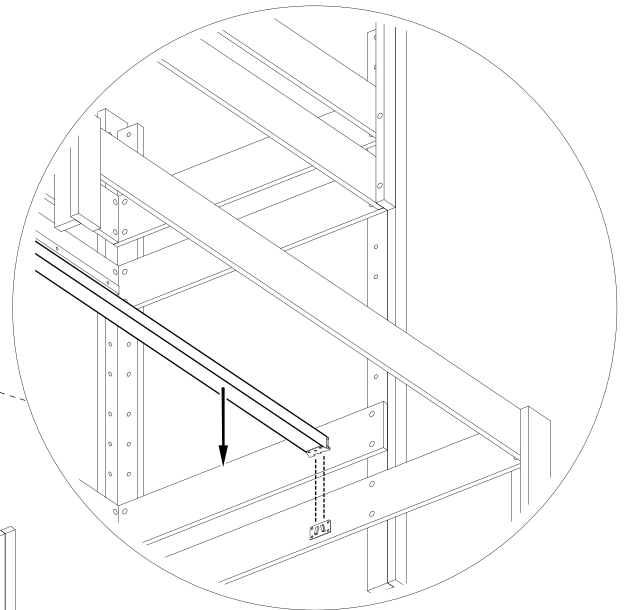
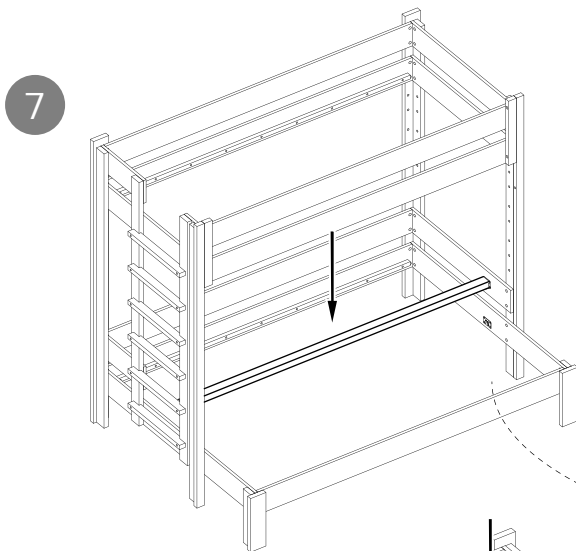
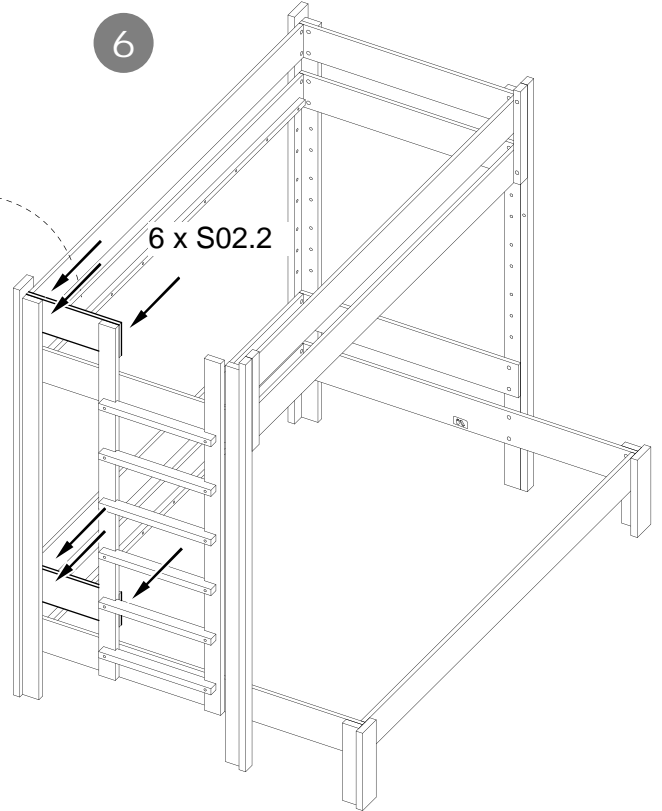
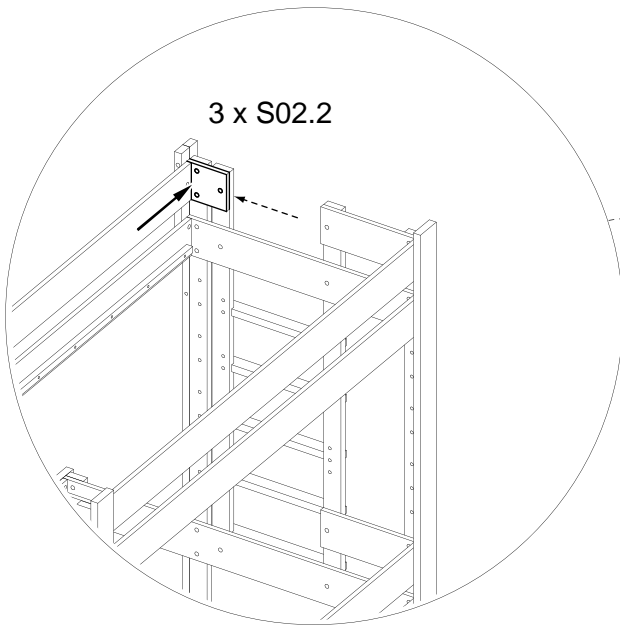

Die Wandbefestigung

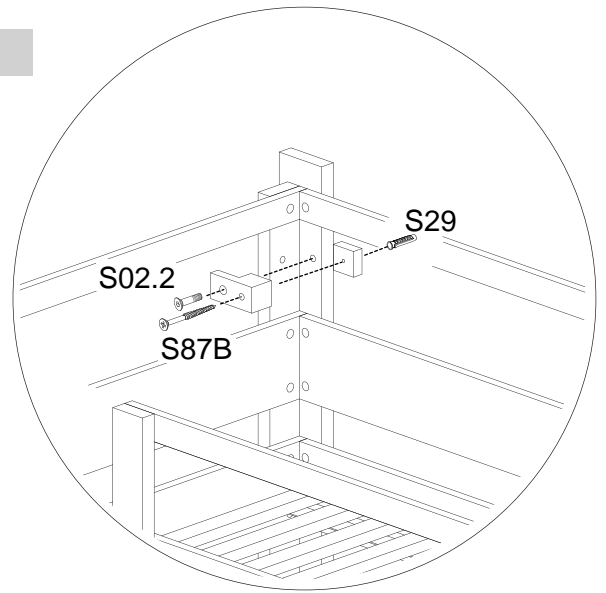

2 x S02.2
2 x S87B
2 x S29

