

Rocking chair

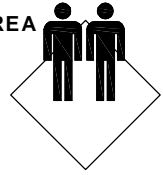

FLOOR AREA
2.5M X 3M



REQUIRED ASSEMBLY TOOLS

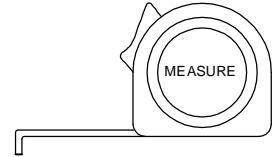
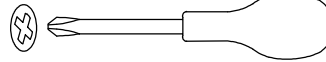
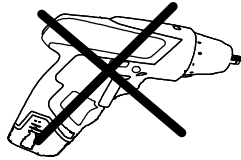

ASSEMBLED DIMENSIONS

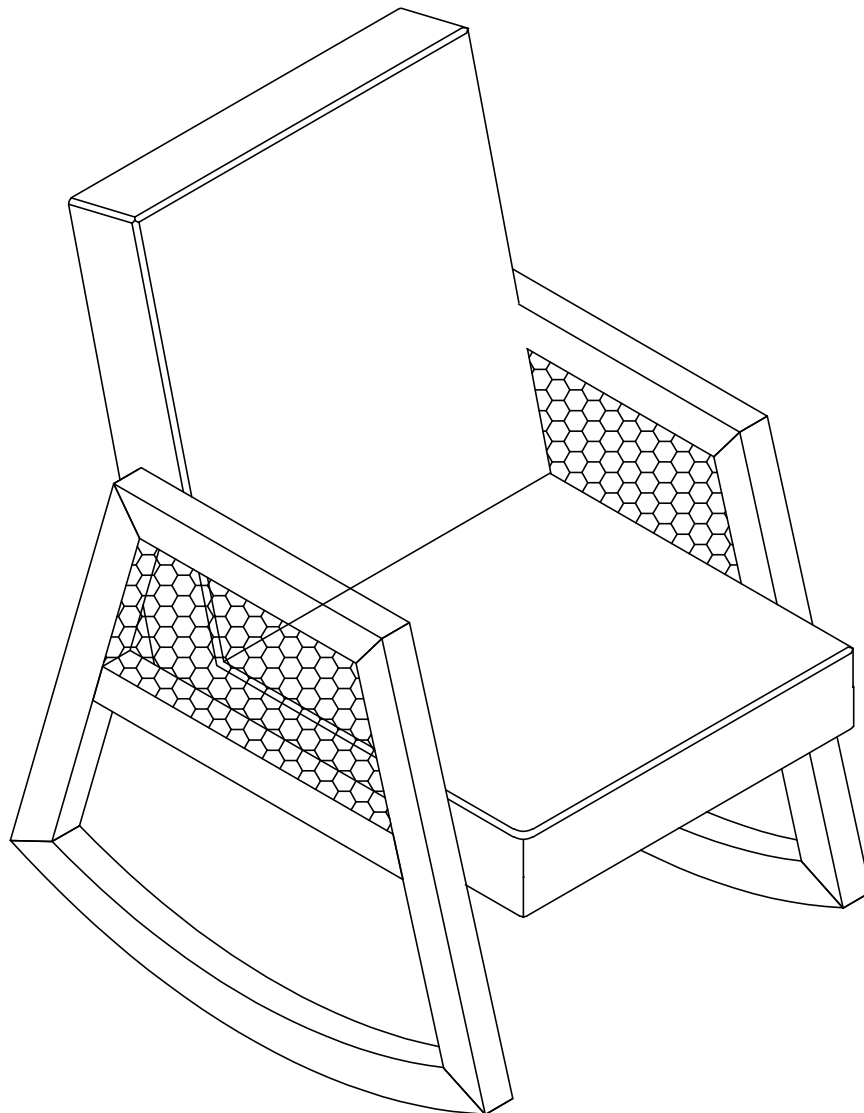

Rocking chair

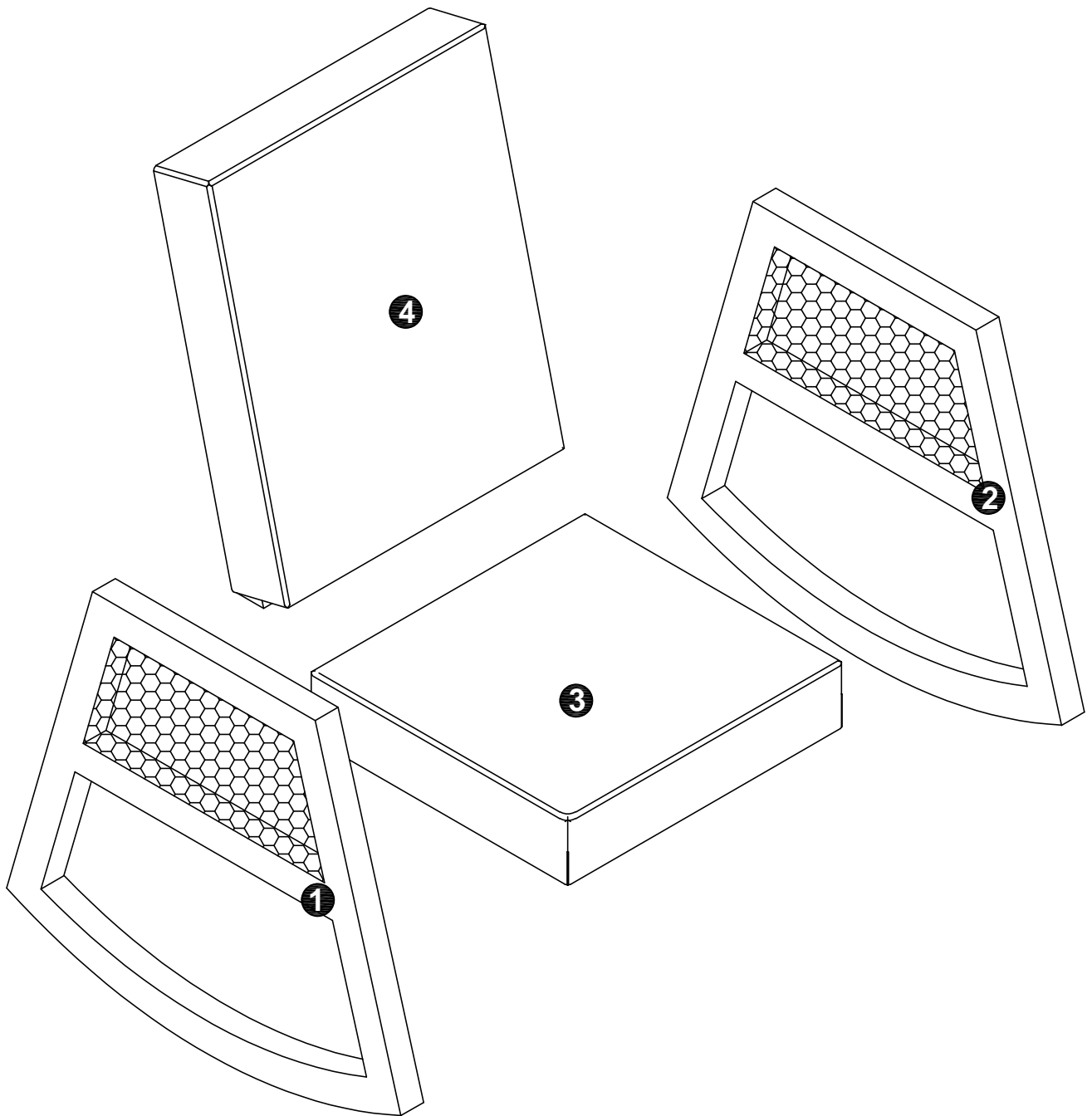

Rocking chair

NO.	PARTS LIST	QTY	NO.	PARTS LIST	QTY
①	Left side	1	③	seat pad	1
②	Right side	1	④	back rest	1

HARDWARE LIST

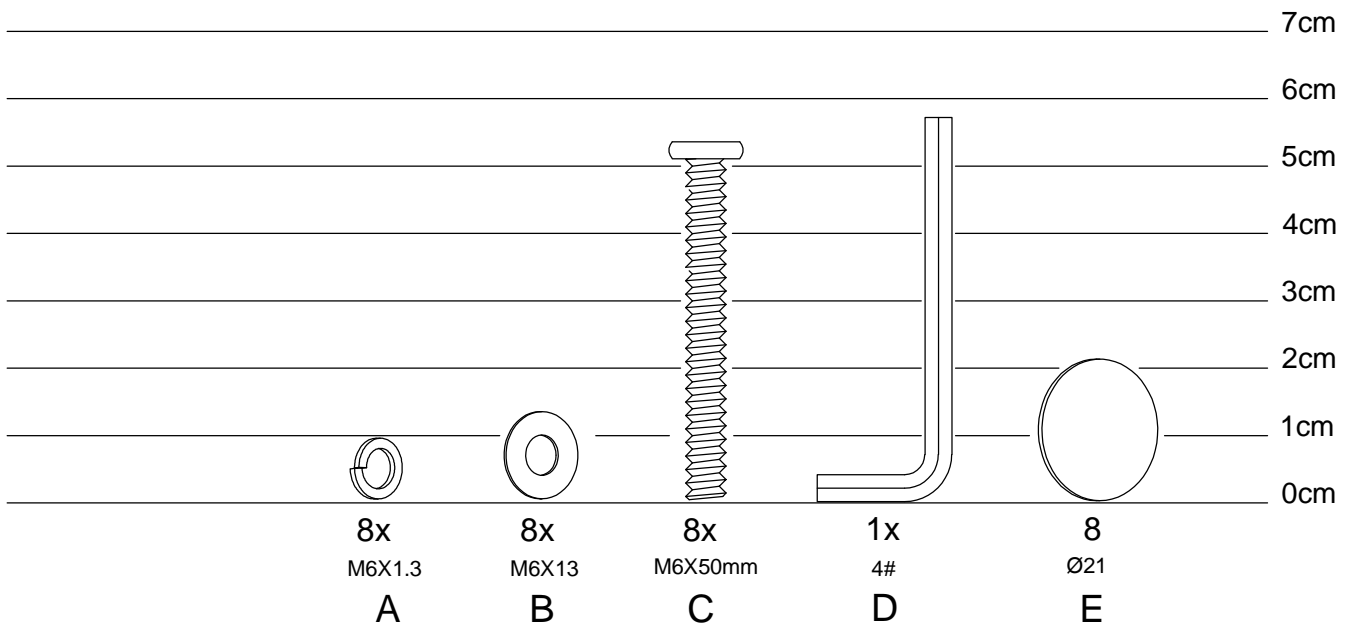

Rocking chair

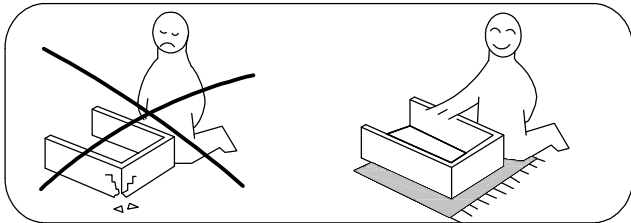
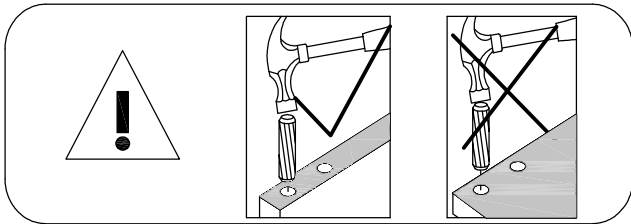
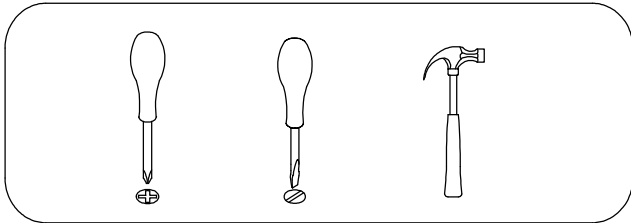

TIPS FOR FITTING CAM-LOCKS AND CAM-PILLARS

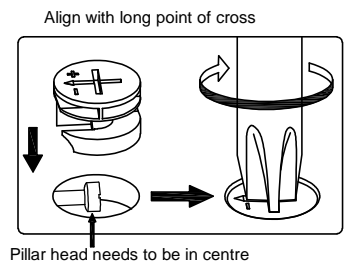
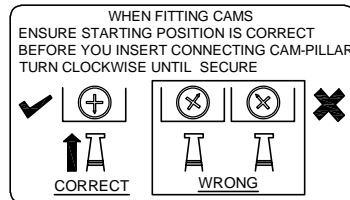
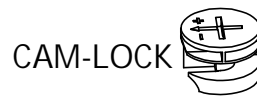

CAM-PILLAR

Tighten until shoulder is flush with panel. Do not overtighten or undertighten (see example below)

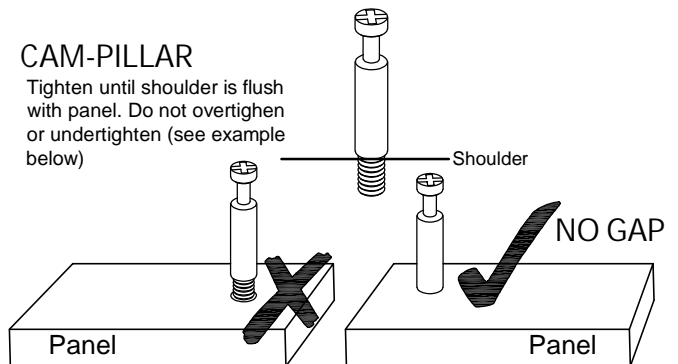

Rocking chair

STEP 1

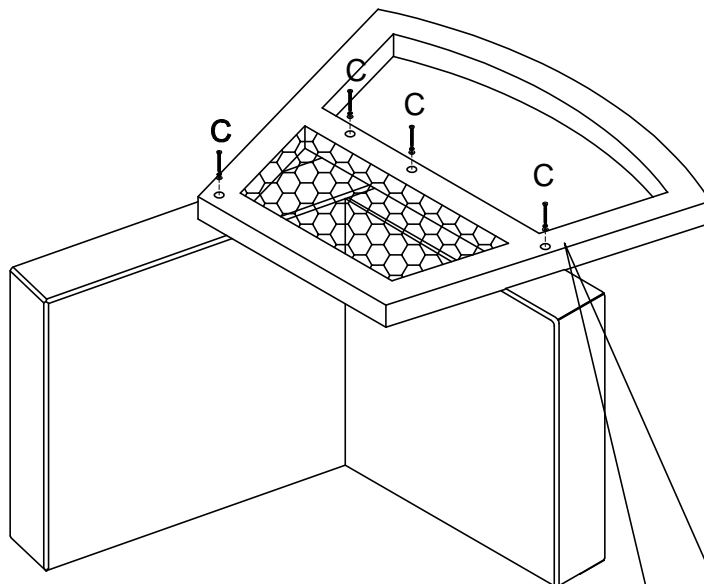

STEP 2

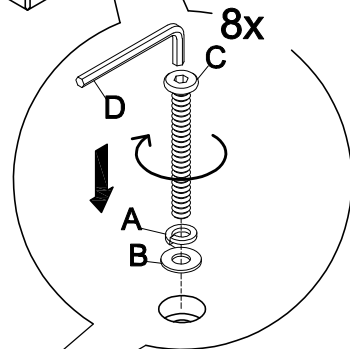
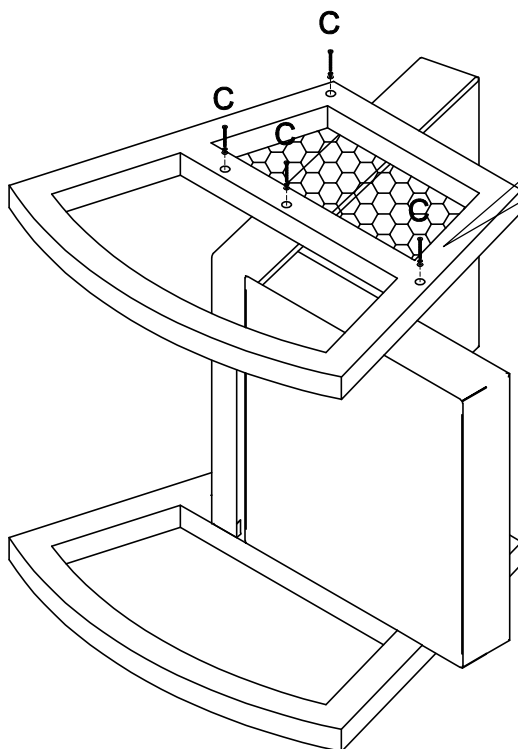

Rocking chair

STEP 3

